



WL 2000

Everyone is health conscious these days. So, you want your staff, customers and visitors to have access to high quality drinking water – but you don't want any hassle. We can offer a refreshingly simple answer: **The WL 2000.**

The WL 2000 mains-fed water dispenser, delivers an instant and constant supply of high quality drinking water.

Because the WL 2000 unlike bottled water coolers, is mains-fed, it does away with the problems of storage, lifting heavy water bottles, degradation and sanitisation, not to mention running out.

Instead, you get features such as ergonomic design that complements every environment and 'direct chill' technology to guarantee fresh water every time. With cost savings in terms of supplies and precious time over bottled water coolers, Waterlogic makes everyone's life easier.

Features: WL 2000

- Direct chill technology
- Basic water purification by carbon filtration (1 micron)
- Large drip tray (1.4 litres capacity)
- Constant supply of chilled filtered water
- Power-on indicator light



Tel: 02920 809090
email: productinfo@phs.co.uk

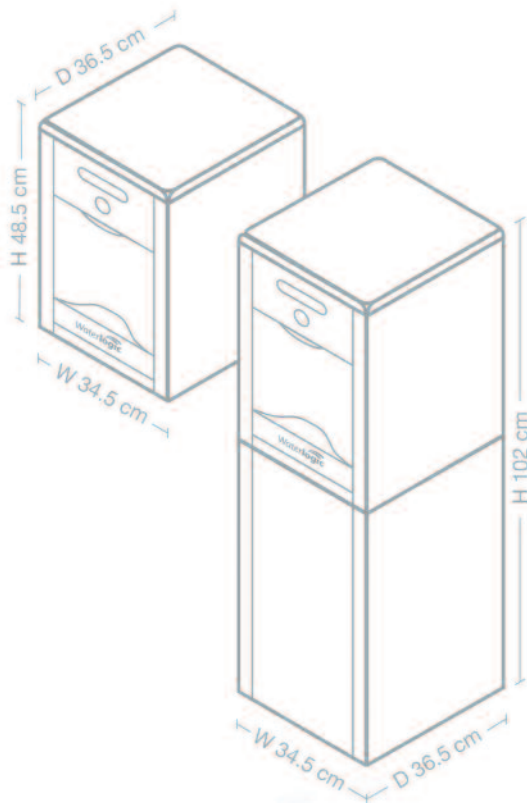

Options: WL 2000

The WL 2000 is available in the following:

Colour:
Silver/charcoal grey

Water:
Cold only

Size:
Freestanding or table top

Cup stack unit:
Black, white or silver

Machine weight

WL 2000 cold only freestanding: 22kg
WL 2000 cold only table top: 20kg

Installation requirements

To ensure that the Waterlogic machine can be installed quickly and smoothly in your proposed location, each machine will require a 13 amp (240 AC) switched socket which should not be more than one metre from the machine.

Each plumbed water machine needs to be supplied with water from a rising main. Machines cannot be connected to a storage tank water supply. The pipe work should ideally be no more than one metre from the machine although our in-house service team are able to install machines in the majority of locations. Pipe work must be terminated with a 15mm BS1010 stopcock.

Technical Information

